

PLAN

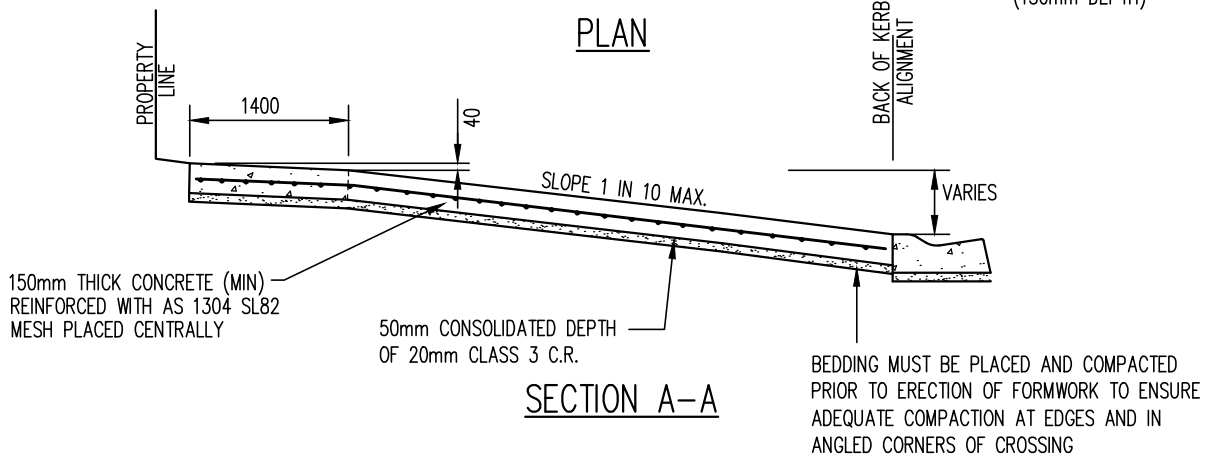

NOTES

1. CONCRETE STRENGTH TO BE F'C=25MPa, SLUMP = 80mm MAX.
2. CROSSING TO HAVE A NON-SLIP FINISHED SURFACE.
3. DOUBLE DRIVEWAY IS TWO DRIVEWAYS WITH INNER SPLAYS DELETED AND 600 WIDE GAP INFILLED WITH CONCRETE AND CAST INTEGRALLY WITH ENTIRE CROSSING
4. IF A>2000mm PROVIDE CONSTRUCTION JOINT AT A/2.
5. EXPANSION MATERIAL TO BE BIFB OR SEMI-RIGID CCPF (150mm DEPTH).
6. IF SIDE BOUNDARY IS AT AN ANGLE THEN CENTRELINE OF CROSSING IS TO BE PARALLEL TO SIDE BOUNDARY WITH JOINTS ADJUSTED AS REQUIRED (EXCEPT EXPANSION JOINTS)
7. WHERE NO FOOTPATH IS CONSTRUCTED, DRIVEWAY SET OUT IS NOT VARIED.
8. CONTRACTION JOINTS LOCATIONS SHOWN THUS
9. FOOTPATH AND INFILL TO BE FORMED AND Poured AS AN INTEGRAL UNIT.
10. WIDTHS >THAN STANDARD REQUIRE SPECIAL COUNCIL APPROVAL
11. FOR CROSSINGS WITH REVERSE FALL SEE SD 305 FOR MAX. LONGITUDINAL GRADE & DRAINAGE REQUIREMENTS



GREATER DANDENONG

VEHICLE CROSSING DETAIL
INDUSTRIAL
ROLLOVER KERB AND CHANNEL SD 403

LAST UPDATED - APRIL 2015

INFRASTRUCTURE PLANNING

SD 304-E