

CONNECTION TO EXISTING EARTHENWARE PIPE

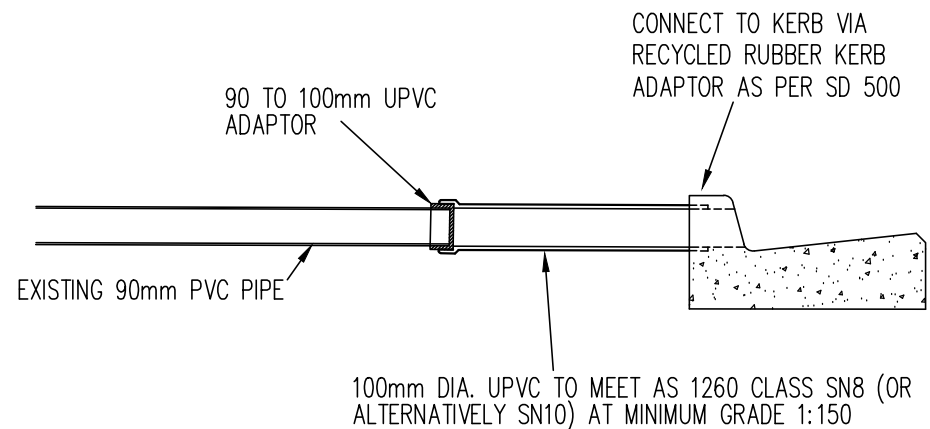

CONNECTION TO EXISTING 90mm PVC PIPE

NOTES

1. ALL JOINTS TO BE SOLVENT WELDED WITH APPROVED SOLVENT.
2. HOUSE DRAIN TO BE MARKED ON SIDE OF THE FOOTPATH , WITH APPROVED STAMP.
3. END OF HOUSEDRAIN TO BE EXTENDED 500mm INTO PROPERTY AND TAPED OR CAPPED.
4. HOUSE DRAIN TO BE INSTALLED 5.0m FROM LOW SIDE OF BLOCK UNLESS SERVICES INTERFERE.
5. IN SITUATIONS WHERE THERE IS NO FOOTPATH, A PEG IS TO BE INSTALLED AT END OF HOUSEDRAIN.
6. HAUNCHING OF PIPE REQUIRED IF TRENCH INFERIOR.
7. WHERE PIPE NOT INSTALLED IN SINGLE LENGTH, APPROVED CONNECTORS MUST BE USED.



GREATER DANDENONG

PROPERTY DRAIN CONNECTION
 TYPE 8 – CONNECTION OF EXISTING HOUSE DRAINS
 TO NEW BARRIER TYPE KERB AND CHANNEL

LAST UPDATED – MARCH 2015

INFRASTRUCTURE PLANNING

SD 508-B